



# SUNCOMBE

CIP, BIOWASTE & PROCESS SOLUTIONS

## 300 Litre Solution Preparation Vessel with In-built Wash



Suncombe Ltd, Jade House, Lockfield Avenue, Brimsdown, Enfield, Middlesex, EN37JY, United Kingdom

T +44(0)20-8443-3454 F +44(0)20-8443-3969 E [info@suncombe.com](mailto:info@suncombe.com) W [www.suncombe.com](http://www.suncombe.com)



# SUNCOMBE

CIP, BIOWASTE & PROCESS SOLUTIONS

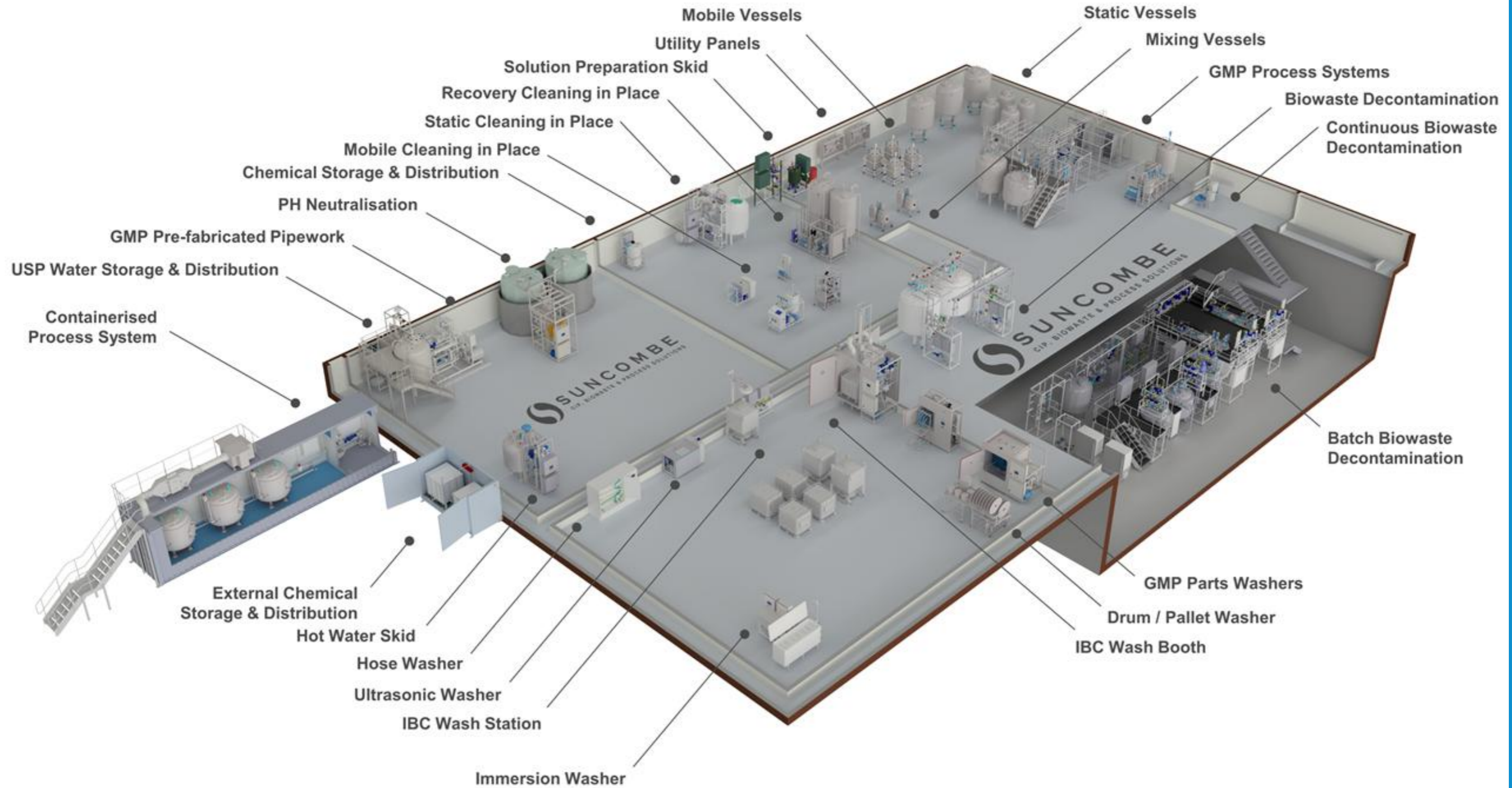

# 300 litre Solution Preparation Vessel with In-built Wash

## Introduction

Developed over the last 30 years, Suncombe The Suncombe 39263 Solution Preparation with In-built Wash is a 300 litre fully sanitary pressure vessel with a mixer, a heating/cooling jacket, mounted on load cells and a self wash pump and skid with the option of custom design and manufacture for your particular requirement. They are high specification units constructed from 316 stainless steel and of sanitary construction.

## Typical Manufacturing Standards

- ASME BPE Construction, fully drainable, crevice free.
- 316 stainless steel contact parts, 304 non-contact parts, T.I.G. Welding

See Manufacturing Standards Datasheet for full details

## Typical Equipment

- 316 Stainless Steel pipework
- Large Sanitary Centrifugal Pump
- Sanitary Valves, manual and air operated
- Steam heating
- Calibrated Instruments

See Equipment Standards Datasheet for full details

## Automation System

A range of automation levels are available, starting from entry level, through mid level PLC and HMI versions, to advanced validateable systems. All levels provide a repeatable automated cycle.

See Automation Standards Datasheet for full details

## Testing

All functions of the equipment would be fully wet and dry tested and test results would be documented in the '**Pre-Factory Acceptance Test**' (FAT) protocol. Following successful completion of this protocol, the client will be invited to the FAT test, where all tests can be repeated or the pre-FAT tests results can be used.

## Validation/ Documentation

The lifecycle approach is adopted (DQ, FDS, HDS, SDS, FAT, SAT, IQ & OQ) with validation being key to every stage of the development process, including Factory Acceptance Testing (FAT), SAT and Qualification.

Image



Model



Dimensions

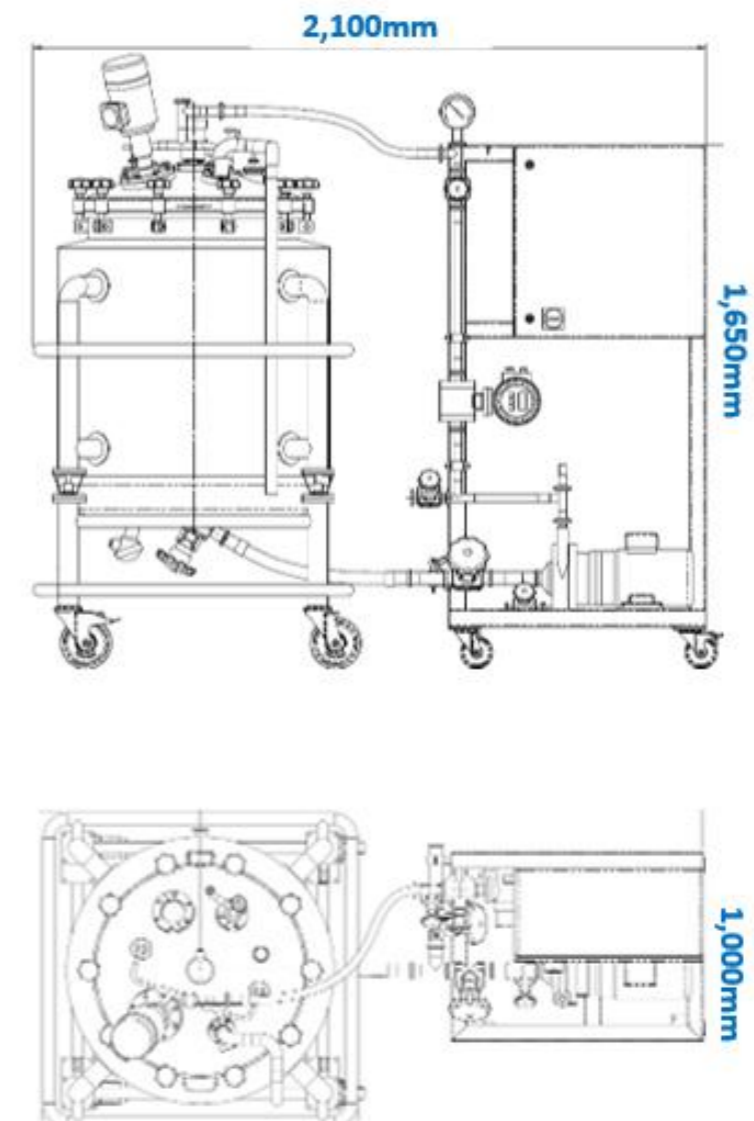

# Mobile Vessel Example Methods for Cleaning and Washing In Place

