

IBCWashBooth™

THE GMP INTERMEDIATE BULK CONTAINER WASHER

The Biotech, Pharma and Critical
Application cGMP Validatable IBC Washer



Overview

These Washers systems provides a robust and repeatable method of washing your process equipment with water and added chemicals, such as detergents and drying.

IBCWashBooth™ systems comprise of a GMP washing chamber, designed to be free draining and self-cleaning, with a sealed door to enclose the equipment during washing and drying. They include integrated washing fluid generation systems including all the necessary liquid inlets, heaters, pumps, valves, dryers, filters pipework and related components and instrumentation to deliver the required washing cycle.

System construction and components are suitable for sanitary use in pharmaceutical, biotech and other hygienic applications.

Systems include a user-configurable recipe based control system to suit a wide range of applications and are pre-assembled and fully tested with operating utility supplies in our works to minimise risk and optimise installation and validation time on-site.

Systems comply with all applicable regulatory standards and are accompanied by a comprehensive suite of documentation covering all aspects of installation, operation and maintenance. Extended documentation packages can be supplied to meet specific validation needs.

Constructed to cGMP, a lifecycle approach is adopted (DQ, FDS, HDS, SDS, FAT, SAT, IQ & OQ), with validation being key to every stage of the development process, including Factory Acceptance Testing (FAT), SAT and Qualification.

Applications

- ✓ IBCs - Intermediate Bulk Containers
- ✓ Trolleys
- ✓ Small Tanks and Vessels
- ✓ Walk in Trolleys for holding parts such as:
 - Sieve Parts
 - Drums
 - Carboys
 - Machine Covers
 - Machine Change Parts
 - Pipework Flexibles
 - Solid dose equipment
 - Small to medium sized parts
 - Parts Washing baskets for Dosing pumps, Hoses, Swing bends, Valves, Clamps and fittings, Utensils, Filters housings
- ✓ and many more in Pharmaceutical, Bio-Waste and other Critical process industries.

GMP Washer Construction

- ✓ FDA approved components with no threads and triclamp connections
- ✓ ASME BPE 316L no dead legs, fully drainable, material & weld traceability
- ✓ ASME BPE chamber design
- ✓ Control and instrumentation to GAMP5
- ✓ Repeatable, validatable client configurable sequences
- ✓ Riboflavin proof of coverage

IBC Washbooth™ DATASHEET

Version 3.12



Welcome

Since our foundation in 1961, Suncombe has pioneered the development of innovative solutions for Cleaning In Place, BioWaste decontamination, GMP Washers, GMP skids, Sanitary Tanks and Vessels. The business continues to be privately owned and managed day to day by Dave Adams and Steve Overton.

Supporting Dave and Steve is a close-knit, dedicated, highly motivated and long-standing team encompassing a wealth of technical experience and knowledge in all relevant disciplines, including design, manufacture, testing, installation, validation, documentation and after-sales support. All of our work is carried out across our own facilities north of London near Stansted Airport. The team employ the very latest techniques, standards and best in class solutions. Having such a strong team allows us to offer the ability to carry out all of our work in-house, under our direct control and quality management systems, ensuring that we own and preserve all the knowledge and experience gained with every project and offer continued support for all our installed systems throughout their lifetime.

Our Equipment

Our policy is to re-invest much of our profits into continuous development of our staff and our facilities, together with Research and Development to provide the optimum technical solutions for our clients requirements.

Our Clientele

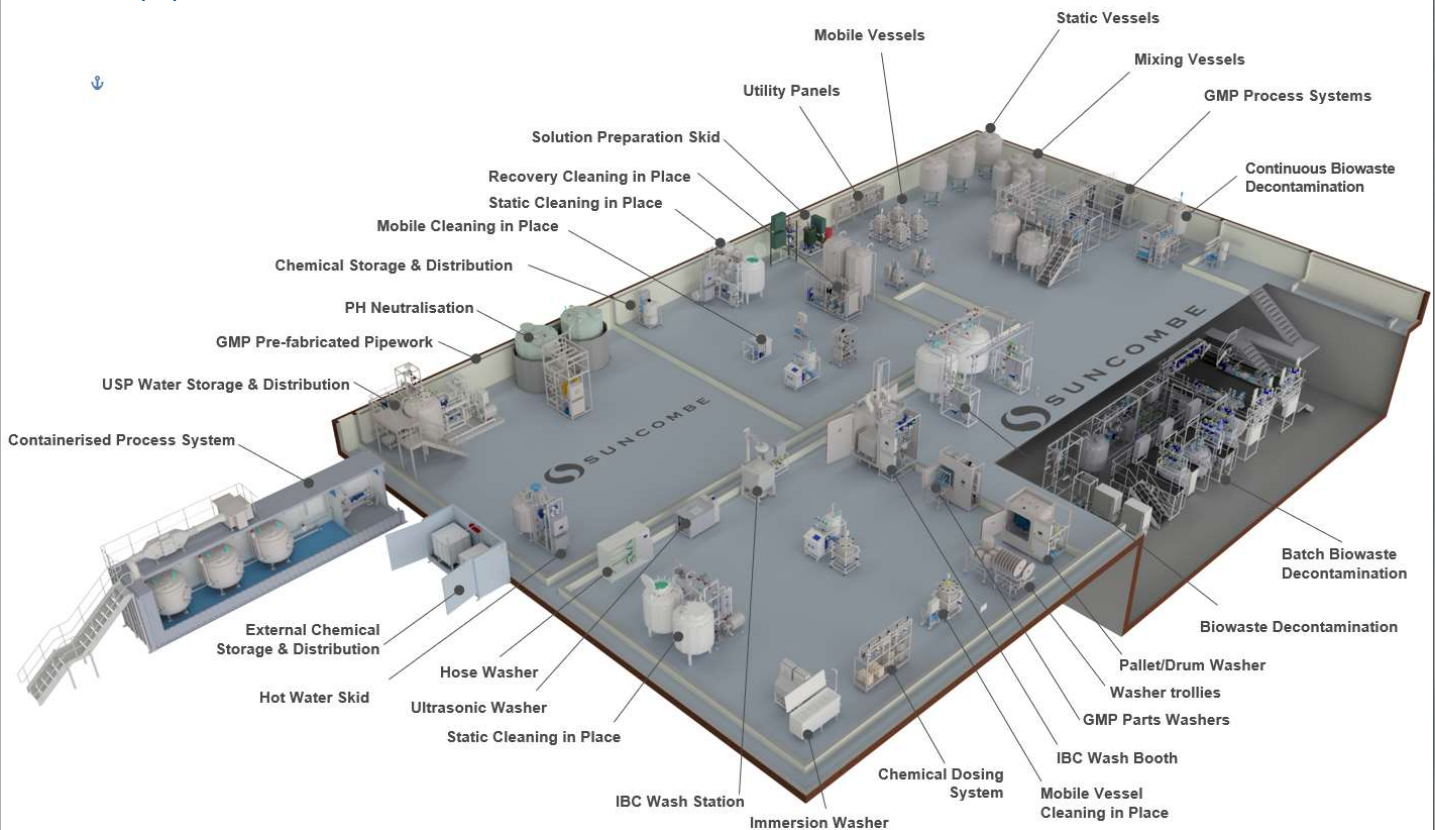

Suncombe Ltd

Suncombe House, Unit B Woodside Industrial Estate, Dunmow Road, Bishop's Stortford, CM23 5RG, United Kingdom
T +44(0)20-8443-3454 F +44(0)20-8443-3969
E info@suncombe.com W www.suncombe.com

IBCWashbooth™ DATASHEET

Version 3.12



Key Features	Benefits
Sanitary 316L stainless steel construction and components	Wash fluids are maintained at the highest sanitary standards complying with ASME BPE offering guaranteed surface finishes with diaphragm valves, full material traceability, weld maps and tables and welding dossier.
Sanitary Washing Chamber	The chamber is constructed from 316L stainless steel and is designed to be free draining and self-cleaning. All chamber corners are formed as 50mm radiuses.
Washing Chamber Dimensions	The BoothWasher™s & IBCWashBooth™s are available with a range of chamber sizes
Spray Washing	Employing a combination of specially developed variable duty spray technologies, the washer provides high energy impingement washing together with low energy flushing chosen by a simple recipe selection. They ensure total coverage of all surfaces, including both internal and external faces using high impact accurate spray targeting, resulting in repeatable and reliable washes.
Doors	Available with hinged or sliding doors - single door or two doors for pass through. An automatic locking system prevents the door from opening during use and after use only when reaching a configurable threshold temperature. On two door versions the doors are interlocked so that they cannot be opened together.
Door Seals	Compressed air inflatable FDA approved door seals provide an airtight, leak free method of sealing, with an interlock to prevent inflation when the door is open and continuous seal integrity monitoring to ensure full containment throughout the cycle. The seals are captive in a recessed channel around the stainless steel door, this ensures correct seal positioning over a long time period.
Variable Duty Wash Pump	316L Stainless Steel Heavy Duty Sanitary Washing Pump with Variable Speed Drive to allow speed control to vary the delivery flowrate and pressure from the recipe, complete with PID loop and automatic impellor casing drain valve. The flow rates and pressures on the washers are fully variable and would be optimised during commissioning to use the lowest flow/pressure/energy required to achieve
Siemens PLC and 12" colour HMI with options for additional HMIs	Control hardware is industry standard and supported worldwide by Siemens. Ethernet interface included for transfer of critical operating variables to other systems. Designed to enable integration to third party equipment or higher level control system. Versions also available with remote I/O for control by clients control system.
Suncombe SmartWash™ software	Control software specification has been developed and proven over many years for CIP applications and includes a wide range of user or administrator configurable parameters to enable customised cleaning recipes, including water flow, pressure, time, temperature, chemical concentration and many more. User passwords, Active Directory, Audit Trails, Electronic CIP batch reports for local or network storage are possible. User interface screens and process visualisation is simple, intuitive, clear and comprehensive. Remote access options are possible if required. Software complies with FDA 21CFR and EU GMP regulations.
Loading	Available as pit mounted for floor level access or floor mounted for fork lift or pallet truck loading. Conveyorized AGV system can also be incorporated.
Equipment Trolleys	Standard and custom trolleys are available for mounting equipment for cleaning. Custom designed trolleys are 3D simulated and Riboflavin tested to confirm 100% spray coverage.
Standard Trolleys	Standard trolleys are available for drums, kegs, hoses etc.
Single-pass or Recirculation options	Wash fluids can be immediately discarded to waste after use ("Single Pass") or may be recirculated to reduce overall water and energy consumption.
Steam or electric water heating options	Heating energy may be derived from most convenient and cost-effective source.
Heated Solution Preparation	Heated solutions can be batch made up
USP Water	1, 2 or 3 water inlets for Soft Water, Purified Water and Water for Injection. Water can either fill system or bypass for direct application.
Continuous monitoring of key parameters	Wash process is highly repeatable and validatable.
Variable chemical dosing	Delivery of 1, 2, 3 or 4 chemicals into wash fluids is controlled.
In-line or batch chemical dosing	Chemical solutions are batch made up using volume ratio validated method with flowmeter. Option for conductivity concentration verification.
Air Drying	Hot air drying system for remote location to dry after liquid phases
Plug 'n' Play	Fully integrated with comprehensive in-house testing to ensure fast start up on site
Drain Solution Cooling	Water quench or coolers can be added for drain cooling.
Air Purge	Includes air purge facility to evacuate all water from the CIP pipework
Fully Drainable	Automatic valves to fully drain entire skid including pump casing
Instruments	Sanitary instruments of Endress and Hauser/Mettler Toledo or equivalent with full material and calibration certification.
Final Rinse Confirmation	Final Rinse Conductivity to confirm completion of Cycle
Spray System	Rotating spray bars are used to provide external and internal cleaning of the parts. The rotating action ensures 100% coverage of the items being cleaned (and the wash booth itself) at a maximum impingement.
Thermal Insulation	The chamber wall and door are fitted with asbestos-free and chlorine-free insulation to minimise external temperatures.

IBCWashbooth™ DATASHEET

Version 3.12

Washer Images

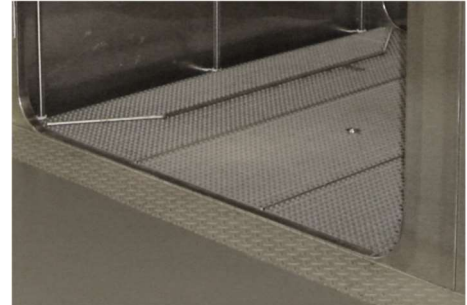

Notes

- Single Door or two door pass through
- Washing compartment can be left or right handed
- Mounted in pit for floor level entry
- Split Butterfly Valve Interfaces Options
- AGV Conveyor Loading Options
- Lid Removal Options

Dimensions

These are typical only and should be confirmed.

IBCWashbooth™ GMP Parts Washer	Chamber Dimensions (mm)		Door Dimensions (mm)	
	Width	Depth	Width	Height
IBCWashbooth™ 2000	1800	1800	1460	2000
IBCWashbooth™ 2500	1800	1800	1460	2500
IBCWashbooth™ 2900	1800	1800	1460	2900
Control Cabinet on Left or Right	1800	1000	1800	1500

Layout Drawing

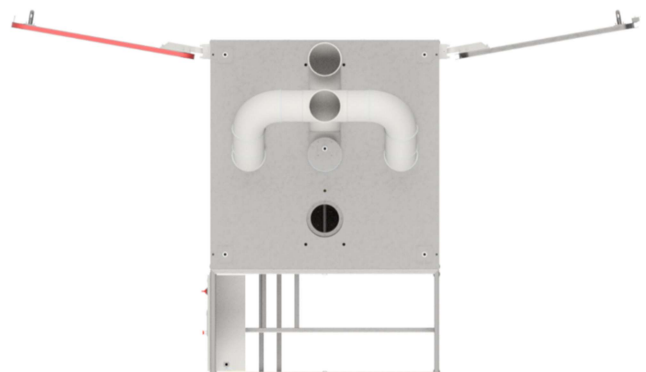

IBCWashbooth™ DATASHEET

Version 3.12



Washer Mounting Options Pit Mounted Floor Level Entry

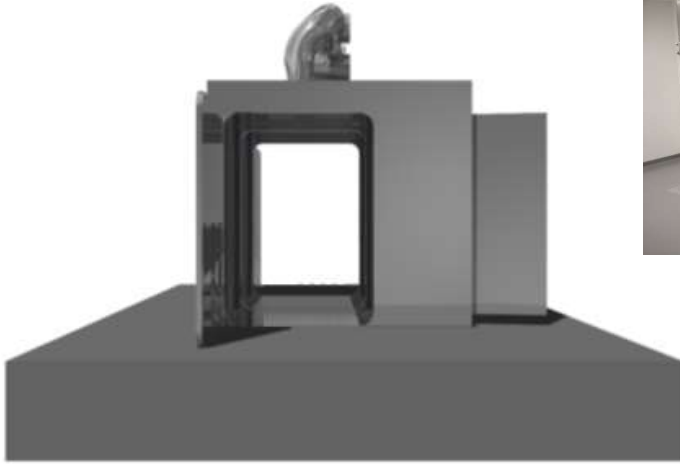

Washer Mounting Options Pit Mounted Above Floor Entry



Single Door or Two Door Passthrough

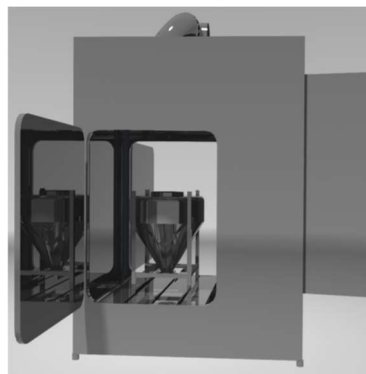
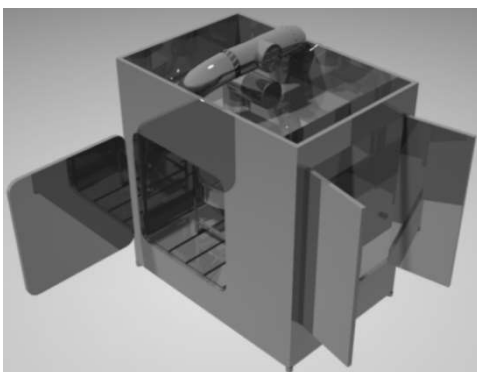

IBCWashbooth™ DATASHEET

Version 3.12



IBCWashbooth with sliding doors

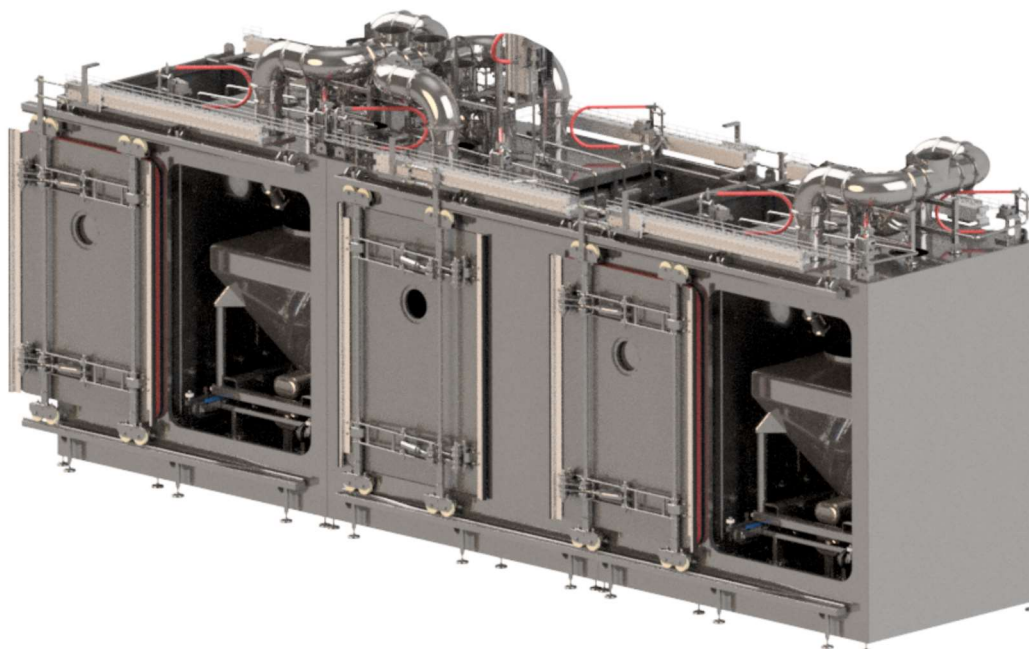

IBCWashbooth with Automatic Split Butterfly Valve Opening



IBCWashbooth Drum and Parts Trolleys

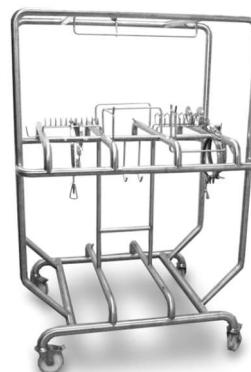

Control and Automation System

Renowned for their ease of operation and versatility, Suncombe systems are designed and manufactured for reliability, repeatability and longevity, whilst complying with the highest international regulatory standards. With dedicated in-house automation personnel for control design and software, Suncombe engineers have tremendous experience in incorporating a broad range of control solutions to suit your specific control requirements.

Developed to the GAMP 'V' model (Verification and Validation), system life cycle approach, which links the three main qualification activities (installation, operation and performance) back to the design process, the system software is produced in house by qualified software engineers, encompassing software development standards, quality control systems and change control during and post development.



Standards and Guidelines

- ✓ GAMP Guidelines
- ✓ FDA 21CFR11 Compliance
- ✓ ASME BPE
- ✓ EU Machinery Directive
- ✓ EU Low Voltage Directive
- ✓ EU cGMP Guidelines
- ✓ EU EMC Electromagnetic Compatibility Directive
- ✓ IEC 61131 for PLCs
- ✓ EN 60204 Safety of machinery
- ✓ EN 60439 Low Voltage Switchgear
- ✓ CE and UKCA Marks

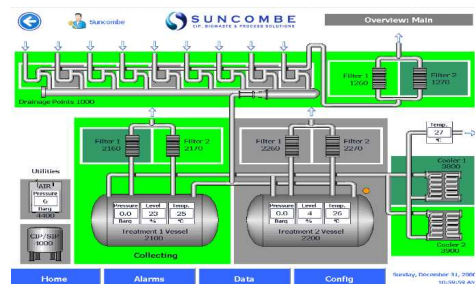

Typical Operator Interface



