

IBCWashStation™

THE GMP INTERMEDIATE BULK CONTAINER WASHER

The Biotech, Pharma and Critical Application cGMP Validatable IBC and Tote Washer for Efficient, Reliable, and Customizable IBC Washing



Overview

The Suncombe IBCWashStation™ systems provides a robust and repeatable method of Washing, sanitising, sterilising and drying intermediate bulk containers (IBCs).

IBCs are used in powder and bulk material handling processes, to transport, process and store various materials, including chemicals, pharmaceuticals, and food products. These containers can become contaminated with residues, bacteria, and other substances that can compromise the integrity of the materials.

An IBCWashStation™ includes integrated washing fluid generation systems including all the necessary liquid inlets, heaters, pumps, valves, dryers, filters pipework and related components and instrumentation, construction and components are suitable for sanitary use in pharmaceutical, biotech and other hygienic applications.

Including a user-configurable recipe based control system which combines liquid flow, pressure, temperatures and chemical energy to provide a repeatable wash of your IBC internals, the cleaning process can be customized to meet specific requirements.

Systems are pre-assembled and fully tested with to minimise risk and optimise installation and validation time on-site and comply with industry standards, including cGMP and FDA regulations. Accompanied by a comprehensive suite of documentation covering all aspects of installation, operation and maintenance, the system is easy to operate and maintain and can be customized to meet specific cleaning requirements.

Electrical heating now available throughout the range

Applications

Washing, sanitising, sterilising and drying of:

- ✓ IBCs - Intermediate Bulk Containers
- ✓ Totes
- ✓ Pallecons
- ✓ Cube tanks
- ✓ Bulk boxes
- ✓ Intermediate bulk packages (IBPs)
- ✓ Intermediate containers (ICs)
- ✓ Intermediate bulk bins (IBBs)

Sanitary Washer Construction

- ✓ FDA approved components with no threads and triclamp connections
- ✓ 316L stainless steel minimal dead legs, fully drainable, options for material & weld traceability
- ✓ User intuitive, versatile control and instrumentation
- ✓ Repeatable, validatable client configurable sequences

IBC WashStation™ DATASHEET

Version 3.12



Welcome

Since our foundation in 1961, Suncombe Ltd and the **CIPProcess Niche product Division**, has pioneered the development of innovative solutions for Cleaning In Place, BioWaste decontamination, GMP Washers, GMP skids, Sanitary Tanks and Vessels. The business continues to be privately owned and managed day to day by Dave Adams and Steve Overton.

Supporting Dave and Steve is a close-knit, dedicated, highly motivated and long-standing team encompassing a wealth of technical experience and knowledge in all relevant disciplines, including design, manufacture, testing, installation, validation, documentation and after-sales support. All of our work is carried out across our own facilities north of London near Stansted Airport

The team employ the very latest techniques, standards and best in class solutions. Having such a strong team allows us to offer the ability to carry out all of our work in-house, under our direct control and quality management systems, ensuring that we own and preserve all the knowledge and experience gained with every project and offer continued support for all our installed systems.

Our policy is to re-invest much of our profits into continuous development of our staff and our facilities, together with Research and Development to provide the optimum technical solutions for our clients requirements.

Our Clientele



Our Equipment

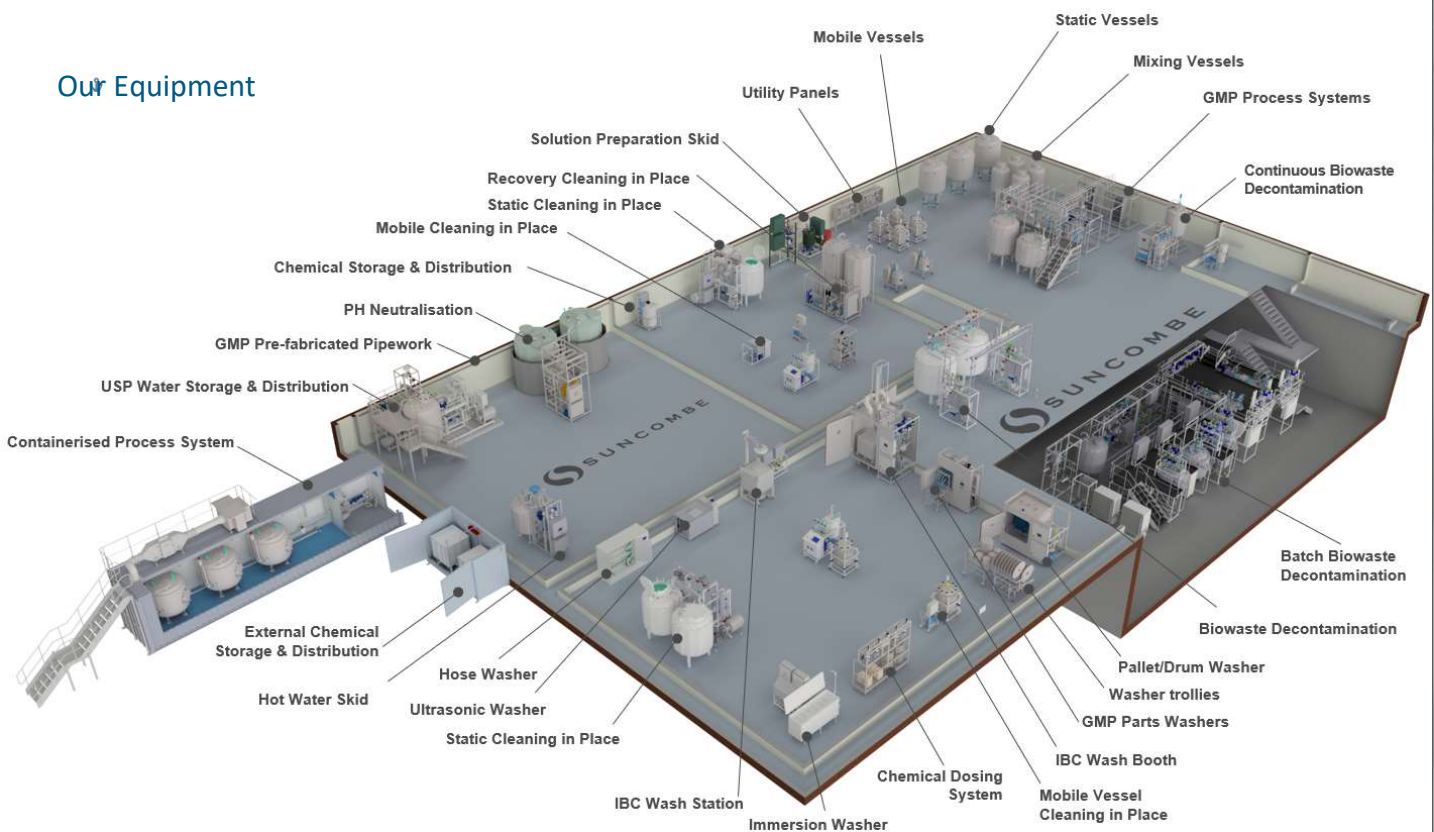

Suncombe Ltd

Suncombe House, Unit B Woodside Industrial Estate, Dunmow Road, Bishop's Stortford, CM23 5RG, United Kingdom
T +44(0)20-8443-3454 F +44(0)20-8443-3969
E info@suncombe.com W www.suncombe.com

IBCWashStation™ DATASHEET

Version 3.12



Key Features	Benefits
Sanitary 316L stainless steel construction and components	Wash fluids are maintained at the highest sanitary standards complying with 316L stainless steel GMP and FDA requirements including minimal dead legs, fully drainable, with options for ASME BPE construction with guaranteed surface finishes with diaphragm valves, full material traceability, weld maps and tables and welding dossier.
IBCWashStation™ Layout	The IBCWashStation™ comprises of a top or bottom entry spray device, an IBC Wash Stand to mount the IBC and a fluid generation skid.
Spray Device	Employing a combination of specially developed variable duty spray technologies, the washer provides high energy impingement washing together with low energy flushing chosen by a simple recipe selection. They ensure total coverage of all internal surfaces, using high impact accurate spray targeting, resulting in repeatable and reliable washes.
Spray Device Insertion options	The choice of spray device insertion option will depend on the type of IBC to be cleaned, the level of contamination, the desired level of automation, and the space available in the wash station.
Wash Stand	The IBCWashStation™ Wash Stand is a device where the IBC is mounted for cleaning. Options are available for straight through or recirculation washing, bottom entry spray devices, drying and heating methodology.
Variable Duty Wash Pump	316L Stainless Steel Heavy Duty Sanitary Washing Pump with Variable Speed Drive to allow speed control to vary the delivery flowrate and pressure from the recipe, complete with PID loop and automatic impellor casing drain valve. The flow rates and pressures on the washers are fully variable and would be optimised during commissioning to use the lowest flow/pressure/energy required to achieve
Siemens PLC and 12" colour HMI with options for additional HMIs	Control hardware is industry standard and supported worldwide by Siemens. Ethernet interface included for transfer of critical operating variables to other systems. Designed to enable integration to third party equipment or higher level control system. Versions also available with remote I/O for control by clients control system.
Suncombe SmartWash™ software	Control software specification has been developed and proven over many years for CIP applications and includes a wide range of user or administrator configurable parameters to enable customised cleaning recipes, including water flow, pressure, time, temperature, chemical concentration and many more. User passwords, Active Directory, Audit Trails, Electronic CIP batch reports for local or network storage are possible. User interface screens and process visualisation is simple, intuitive, clear and comprehensive. Remote access options are possible if required. Software complies with FDA 21CFR and EU GMP regulations.
Single-pass or Recirculation options	Wash fluids can be immediately discarded to waste after use ("Single Pass") or may be recirculated to reduce overall water and energy consumption.
Steam or electric water heating options	Heating energy may be derived from most convenient and cost-effective source.
Heated Solution Preparation	Heated solutions can be batch made up
USP Water	1, 2 or 3 water inlets for Soft Water, Purified Water and Water for Injection. Water can either fill system or bypass for direct application.
Continuous monitoring of key parameters	Wash process is highly repeatable and validatable.
Variable chemical dosing	Delivery of 1, 2, 3 or 4 chemicals into wash fluids is controlled.
In-line or batch chemical dosing	Chemical solutions are batch made up using volume ratio validated method with flowmeter. Option for conductivity concentration verification.
Air Drying	Hot air drying system for remote location to dry after liquid phases
Plug 'n' Play	Fully integrated with comprehensive in-house testing to ensure fast start up on site
Air Purge	Includes air purge facility to evacuate all water from the CIP pipework
Fully Drainable	Automatic valves to fully drain entire skid including pump casing
Instruments	Sanitary instruments of Endress and Hauser/Mettler Toledo or equivalent with full material and calibration certification.
Final Rinse Confirmation	Final Rinse Conductivity to confirm completion of Cycle

IBCWashStation™ DATASHEET

Version 3.12



Typical IBCWashStation™



Typical IBCWashStation™ Installed



Typical IBCWashStation™ Operator Interface HMI

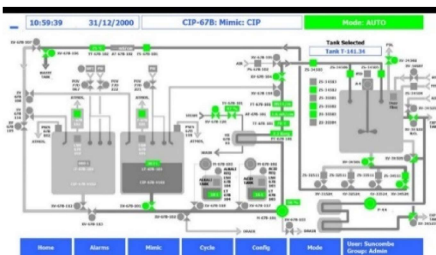

Typical IBCWashStation™ Operator Interface HMI Recipe Configuration

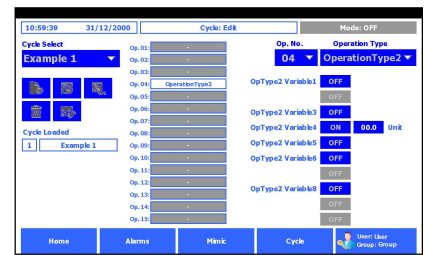
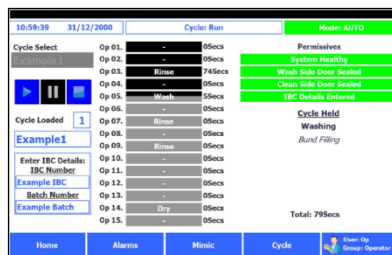

Utilities

Water (Soft, USP, PW, WFI - 1, 2 or 3 waters)	60 litres/min @ 1 bar
Compressed Air (internal regulator)	Minimal use @ 7bar
Air Purge (internal regulator and HEPA filter)	700 Slpm
Electricity	>12 kW 400Vac 3ph+n 50hz. Other voltages available to order
Steam and Condense (if required)	To be confirmed dependant on system duty @ 3 bar for double plate heat exchanger
Drain	60 litres/min @ 1 bar (as per system flowrate)

IBC WashStation™ DATASHEET

Version 3.12

Spray Device Insertion Options

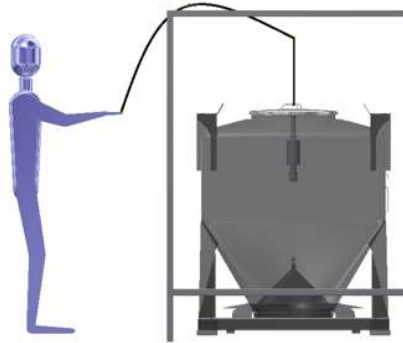
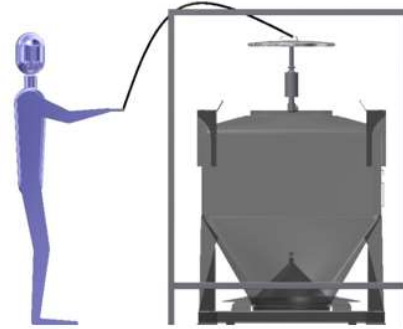

Manual Fitting

Manual Assisted Fitting

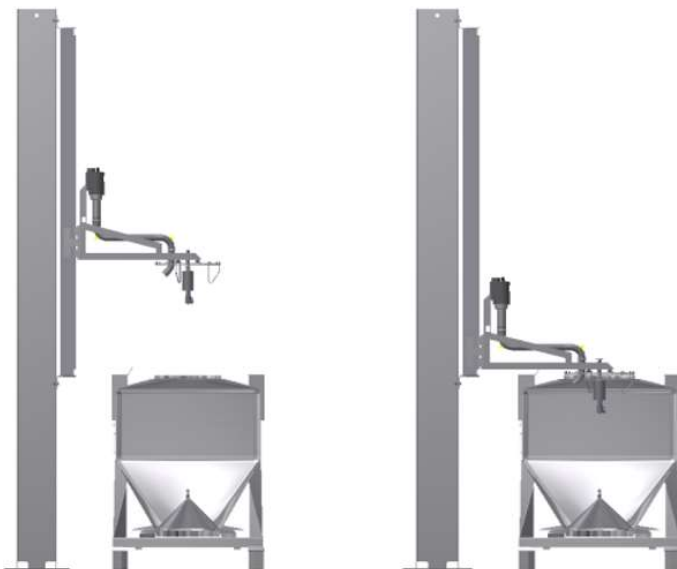

Dropdown from Column Insertion

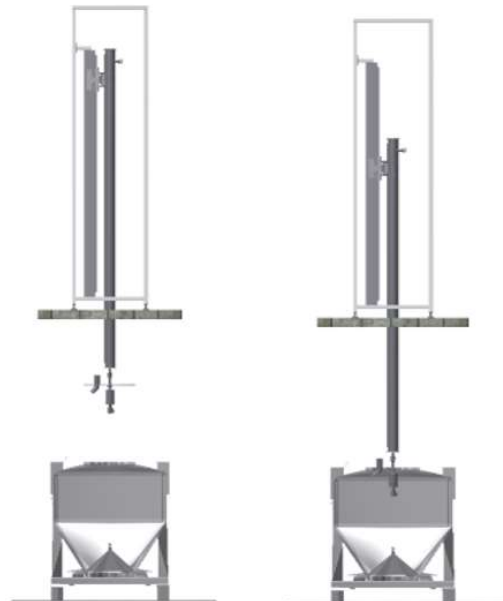

Dropdown from Ceiling Insertion

IBCWashStation™ DATASHEET

Version 3.12



Control and Automation System

Renowned for their ease of operation and versatility, Suncombe systems are designed and manufactured for reliability, repeatability and longevity, whilst complying with the highest international regulatory standards. With dedicated in-house automation personnel for control design and software, Suncombe engineers have tremendous experience in incorporating a broad range of control solutions to suit your specific control requirements.

Developed to the GAMP 'V' model (Verification and Validation), system life cycle approach, which links the three main qualification activities (installation, operation and performance) back to the design process, the system software is produced in house by qualified software engineers, encompassing software development standards, quality control systems and change control during and post development.



Standards and Guidelines

- ✓ GAMP Guidelines
- ✓ FDA 21CFR11 Compliance
- ✓ ASME BPE
- ✓ EU Machinery Directive
- ✓ EU Low Voltage Directive
- ✓ EU cGMP Guidelines
- ✓ EU EMC Electromagnetic Compatibility Directive
- ✓ IEC 61131 for PLCs
- ✓ EN 60204 Safety of machinery
- ✓ EN 60439 Low Voltage Switchgear
- ✓ CE and UKCA Marks

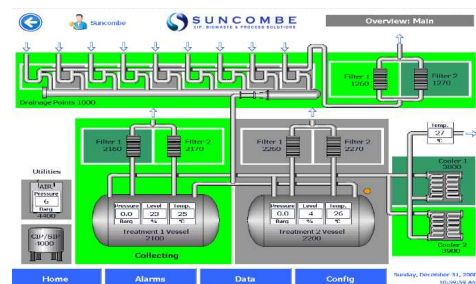

Typical Operator Interface



