



SUNCOMBE
CIP & PROCESS ENGINEERS

UltraWasher™



Suncombe Ltd, Jade House, Lockfield Avenue, Brimsdown, Enfield, Middlesex, EN37JY, United Kingdom

T +44(0)20-8443-3454 F +44(0)20-8443-3969 E info@suncombe.com W www.suncombe.com

www.suncombe.com

About Us

Suncombe Limited is an organization dedicated to the advancement of Clean in Place (CIP) and Hygienic processing technology. We have always targeted leading-edge technologies. Our mission is to utilise forward-thinking expertise that anticipate and satisfy the needs of cleaning and hygienic processing requirements of the future.

Introduction

The Suncombe UltraWasher range has been developed over 40 years of Washing, Cleaning, Sterilising and Drying requirements. UltraWashers are used to provide a method of carrying out high quality, repeatable, validatable cleaning of portable or moveable parts and components that cannot be cleaned in place. The range is based on standard modules with individual units custom designed and built in-house for specific applications.

Versions

- **Parts Washers**—standard or custom designed trays, racks and baskets.
- **Drum Washers**—fixed or removable racks, can include inverters and tippers.
- **Tray/Pallet Washers**—in line or rotary versions. Automatic or manual feed.
- **Combined Units**—any combination of washers can be built into a single unit.
- **Basic Units**—cleaning fluids supplied from a mobile or static CIP system.

UltraWasher Specification

- Floor mounted booth adjustable level
- Loaded manually or by forklift or pedestrian stacker truck
- All stainless steel 316/316L construction with insulation

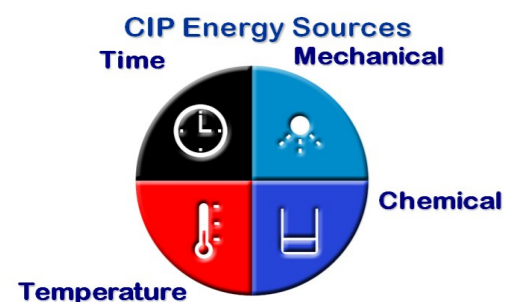

Typical UltraWasher



Typical CIP



Bespoke Wash Trolley



Manual Lids



Internal Cleaning



External Cleaning

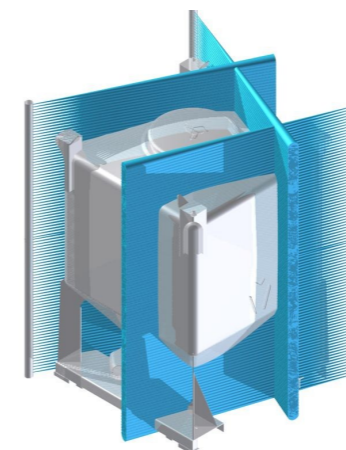

Typical Industries

Food, Dairy, Brewery, Beverage, Pharmaceutical Agro-chemical, Flavourings, Healthcare, Cosmetics, Personal Care, and many other processing industries.

Options

The systems are custom developed around a generic standard so ant options can be included including scavenge pumps and drain pumps.

Available Rinses

Cold Water Rinse, Cold Detergent Rinse, Hot Water Rinse, Hot Detergent Rinse, Cold Sanitiser Rinse, Air Purge

Automation

CIPSuite#1™ - Simple versatile automatic control system with 6 time changeable recipes.

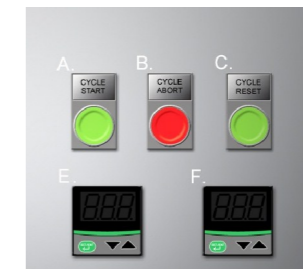

CIPSuite#2™ - Automatic control system with 100 fully configurable recipes, time changeable recipes, I/O faceplates, Mimic diagrams, Printer, Profibus Communications Protocol, Repeatable automatic cycles, User control with passwords, In built troubleshooting and diagnostic ability.

