



BIO WASTE DECONTAMINATION, CLEANING IN PLACE, GMP PROCESS SKIDS AND SYSTEMS, GMP WASHERS & UTILITY PANELS

DELIVERED WITH INTEGRITY SINCE 1961



TEAM

FAMILY OWNED SINCE 1961



STEVE AND DAVE OVERTON
OWNERS/DIRECTORS

- EXPERIENCED
- SKILLED
- DEDICATED
- PROFESSIONAL
- HONEST



DESIGN



FABRICATE

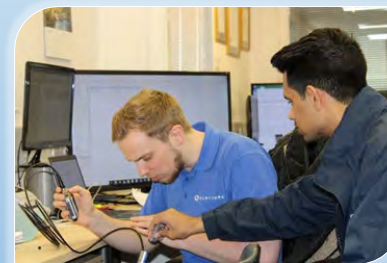

TEST



COMMISSION

NEW FACILITY NEAR STANSTED AIRPORT



*WE ARE PLEASED TO ANNOUNCE THAT ALL
NEW PROJECTS WILL BE CONSTRUCTED IN
OUR NEW FACILITY FROM 2024*

SUSTAINABILITY



ALL SUNCOMBE EQUIPMENT AND SYSTEMS HAVE BEEN DEVELOPED TO OPTIMISE THEIR SUSTAINABILITY AND TO INTEGRATE TECHNIQUES AND TECHNOLOGIES TO MINIMISE THEIR IMPACT ON THE ENVIRONMENT.

ENVIRONMENTAL PRESERVATION



WE ARE PLEASED TO CONTRIBUTE TO THE ENVIRONMENTAL
PRESERVATION OPERATIONS OF:

TREES FOR LIFE

REGENERATING THE WILD FOREST AND PROVIDING SPACE FOR WILDLIFE
TO FLOURISH AND COMMUNITIES TO THRIVE

GLOBAL CLIENTELE



TRUSTED BY 17 OF THE TOP 20 BIOPHARMA COMPANIES WORLDWIDE

Product Portfolio

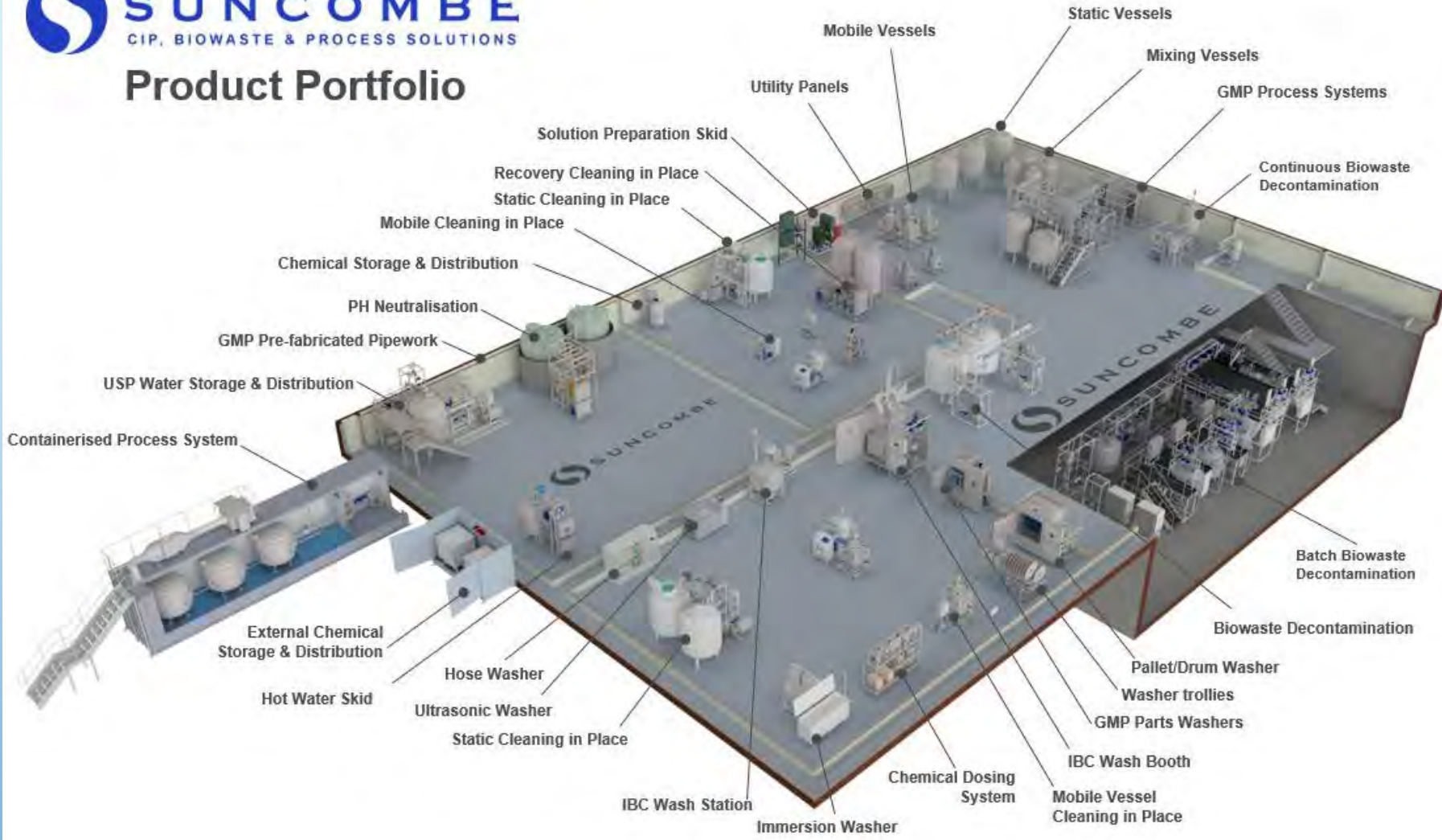

EFFLUENT DECONTAMINATION SYSTEMS (EDS)

ENABLING SCIENTIFIC ADVANCES | PROTECTING OUR ENVIRONMENT

- BIOTECH / VACCINE MANUFACTURE
- UNIVERSITY / R&D CENTRES
- VIROLOGY LABORATORIES
- ANIMAL LABORATORIES



WE ARE PROUD TO HAVE DELIVERED MOST OF THE CATEGORY 4 EFFLUENT DECONTAMINATION SYSTEMS IN THE UNITED KINGDOM

EFFLUENT DECONTAMINATION SYSTEMS (EDS)

BIOSAFETY LEVELS (BSL)

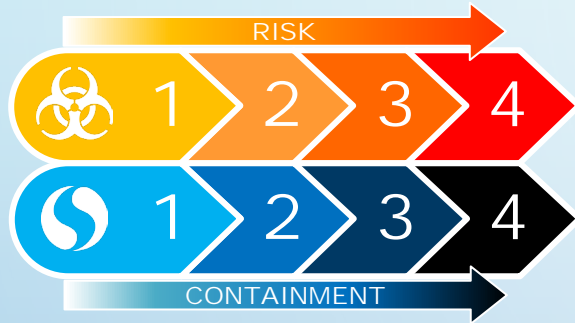

BATCH, CONTINUOUS & HYBRID



HIGH VOLUME



COMPACT

CLEANING IN PLACE CIP



MOBILE

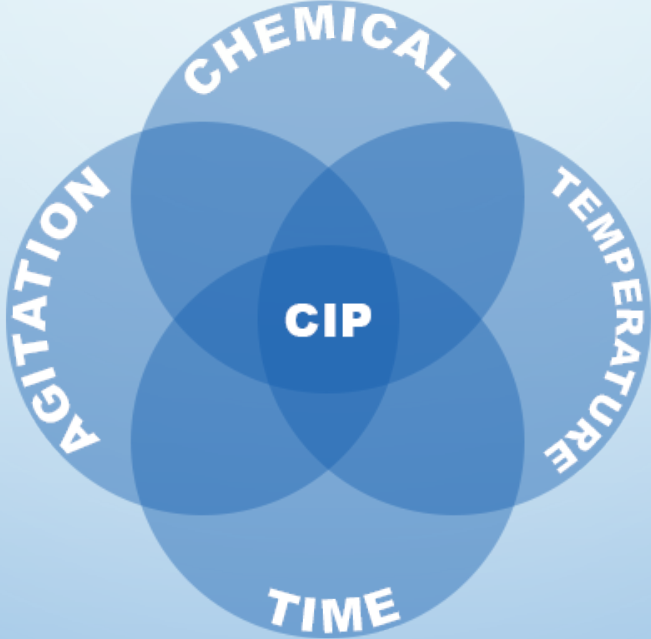

FIXED

WE ARE PROUD TO BE THE OLDEST INDEPENDENT CIP COMPANY
IN THE UNITED KINGDOM

CLEANING IN PLACE CIP

FLEXIBLE SOLUTIONS



ATEX



NO VESSEL



MULTI TANK

WE ARE PROUD TO BE THE OLDEST INDEPENDENT CIP COMPANY
IN THE UNITED KINGDOM



STERILISATION IN PLACE (SIP)



MOBILE



FIXED

GMP WASHERS



- SMALL PARTS
- DRUMS
- PALLETS
- SINGLE DOOR
- PASS-THROUGH
- ULTRASONIC



GMP IBC WASH BOOTHS



- IBC WASHING
- SINGLE OR TWO DOOR FOR PASS THROUGH
- SPLIT BUTTERFLY VALVE DOCKING
- WASHING AND DRYING
- PARTS TROLLEYS AND RACKS



AWARD WINNING ASME BPE cGMP PROCESS SKIDS, SYSTEMS AND TURNKEY SCHEMES

CUSTOM DESIGNS – WE WORK
WITH CLIENTS TO PROVIDE
CRITICAL PROCESS SKIDS,
INCLUDING:

- FINAL FORMULATION & FILL
- STORAGE, MIXING,
PROCESSING AND
TRANSFER
- FERMENTATION
- FILTRATION SKIDS
- SUPER SKIDS
- BLENDING AND DILUTION
- PASTEURISATION

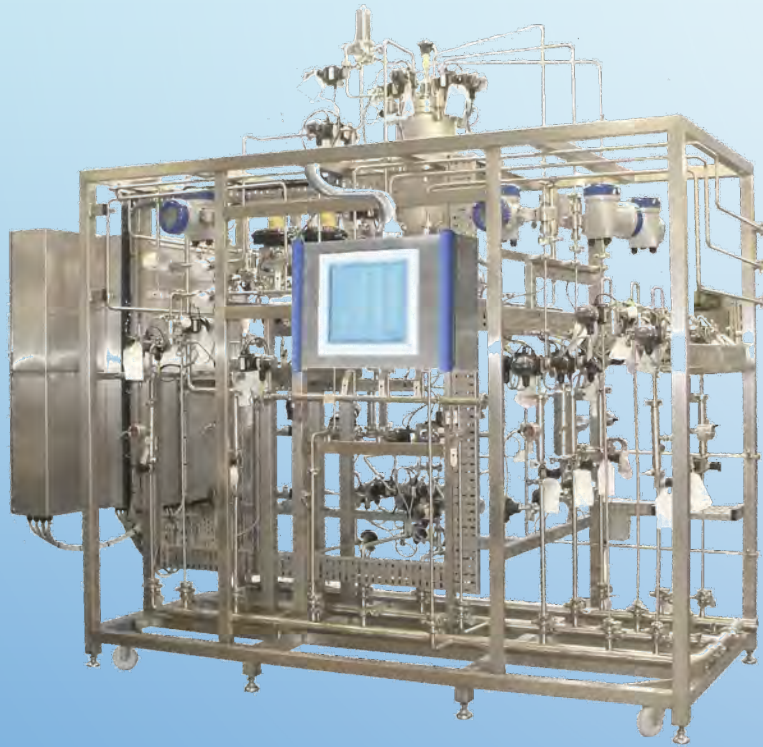

AWARD WINNING ASME BPE cGMP PROCESS SKIDS, SYSTEMS AND TURNKEY SCHEMES

GENERIC AND STANDARD
DESIGNS, INCLUDING:

- USP WATER STORAGE SKIDS
- HIGH TEMPERATURE SHORT TIME (HTST) SKID
- MIXING SKIDS
- POWDER INCORPORATION
- BUFFER AND MEDIA PREPARATION
- SOLUTION PREPARATION
- IBC DISCHARGE STATIONS



UTILITY, TRANSFER AND SERVICE PANELS

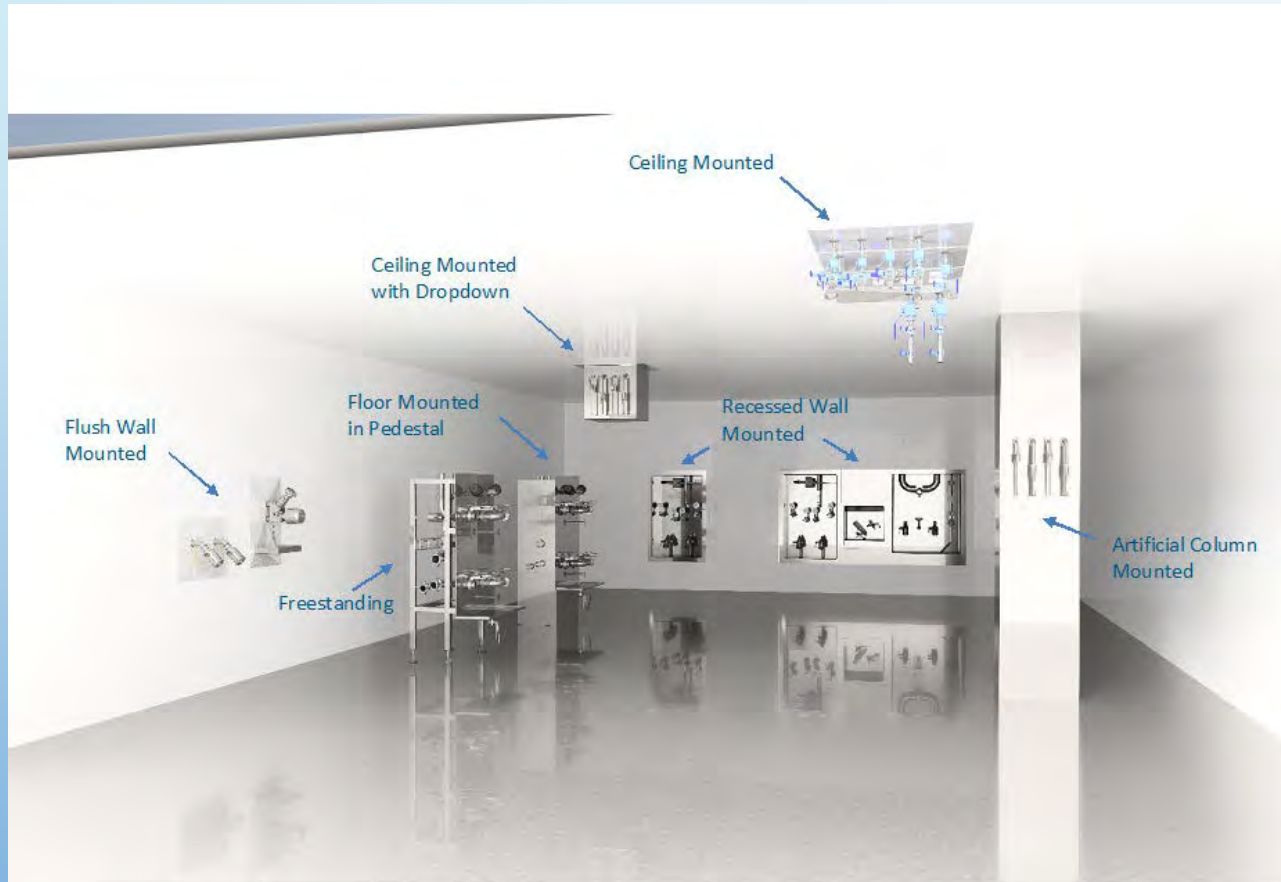

NON GMP SKIDS AND SYSTEMS

- PH NEUTRALISATION SKIDS
- CHEMICAL DISTRIBUTION SCHEMES
- DOSING SKIDS
- PROCESS UTILITY SKIDS
- TEMPERATURE CONTROL SYSTEMS
- HEAT TREATMENT
- LOW PRESSURE HOT WATER
- THERMAL RECOVERY



TANKS, VESSELS, MIXERS



- STATIC AND MOBILE VESSELS
- ATMOSPHERIC AND PRESSURE VESSELS
- JACKETED MIXING AND BLENDING VESSELS
- HEATING AND COOLING VESSELS
- SOLUTION PREPARATION VESSELS
- VESSEL SKIDS



CONTAINERISED SYSTEMS

- MODULAR
- PLUG & PLAY
- FULLY ASSEMBLED
- WEATHERPROOF



cGMP MANUFACTURING INTERNATIONAL STANDARDS



DESIGN – 2D

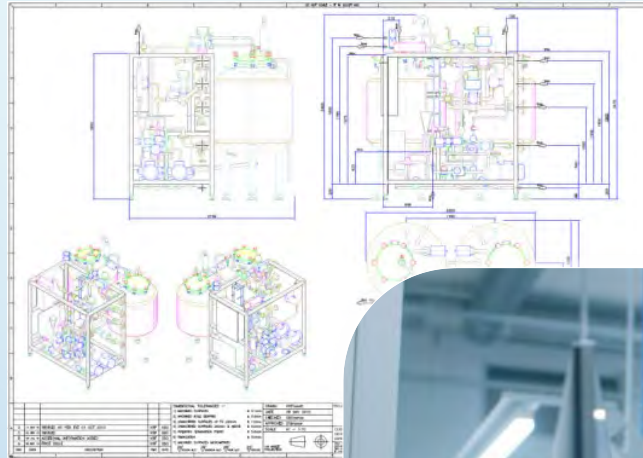
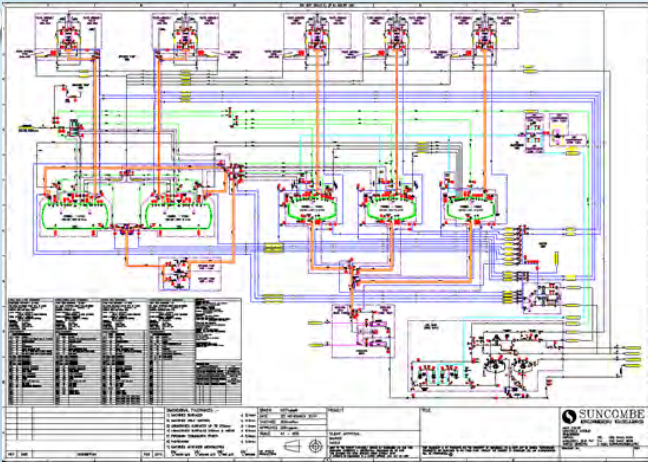

- GENERAL ARRANGEMENTS
- PROCESS FLOW DIAGRAMS
- P&I DIAGRAMS
- SCHEMATICS
- CIRCUIT DIAGRAMS



DESIGN – 3D MODELLING



- VISUALISATION
- LAYOUT OPTIMISATION
- CONFIGURATION PLANNING



 **SOLIDWORKS**



INVENTOR

DESIGN – INTEGRATION

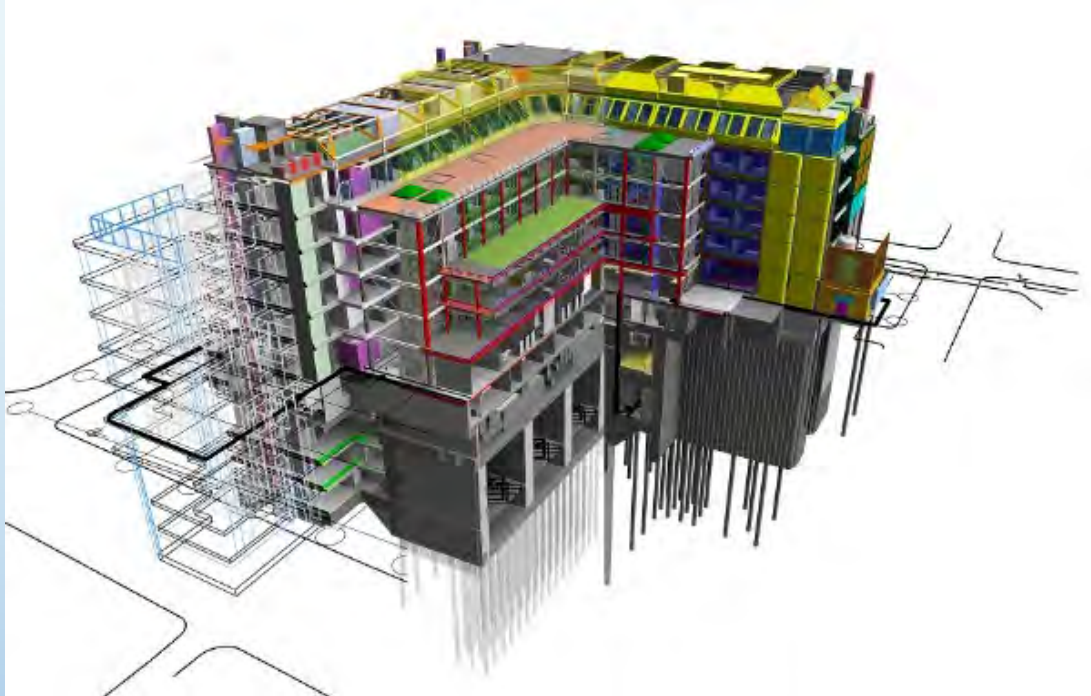
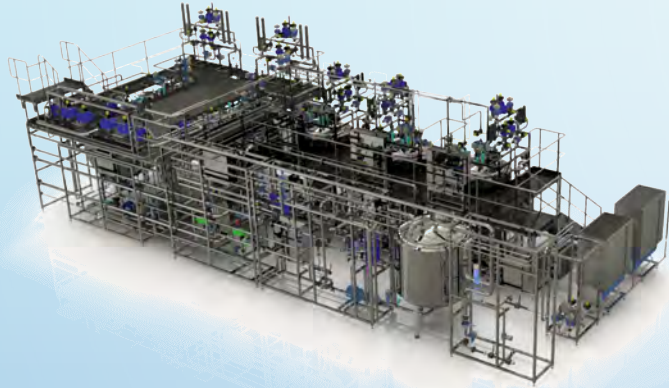

- MODELLING INTERFACES
- AUTODESK REVIT AND EQUIVALENTS
- CONSTRUCTION CLOUD
- BUILDING INFORMATION MODELLING (BIM)



INVENTOR

HYGIENIC DESIGN & CONSTRUCTION



CERTIFICATION



- ✓ CE MARK
- ✓ PRESSURE EQUIPMENT DIRECTIVE (PED) (2014 / 68 / EU)



- ✓ EN 13445



- ✓ PD 5500:2018



...AND MORE

- ✓ ASME VIII

- ✓ ASTM A-269

- ✓ 3A DAIRY

RISK ASSESSMENT



		Impact →				
		Negligible	Minor	Moderate	Significant	Severe
Likelihood ↑	Very Likely	Low Med	Medium	Med Hi	High	High
	Likely	Low	Low Med	Medium	Med Hi	High
	Possible	Low	Low Med	Medium	Med Hi	Med Hi
	Unlikely	Low	Low Med	Low Med	Medium	Med Hi
	Very Unlikely	Low	Low	Low Med	Medium	Medium

- FAULT AND FAILURE ANALYSIS
- HAZID (HAZARD IDENTIFICATION STUDY)
- HAZOP (HAZARD AND OPERABILITY STUDY)
- LOPA (LAYERS OF PROTECTION ANALYSIS)
- SIL (SAFETY INTEGRITY LEVEL)

AUTOMATION DESIGN

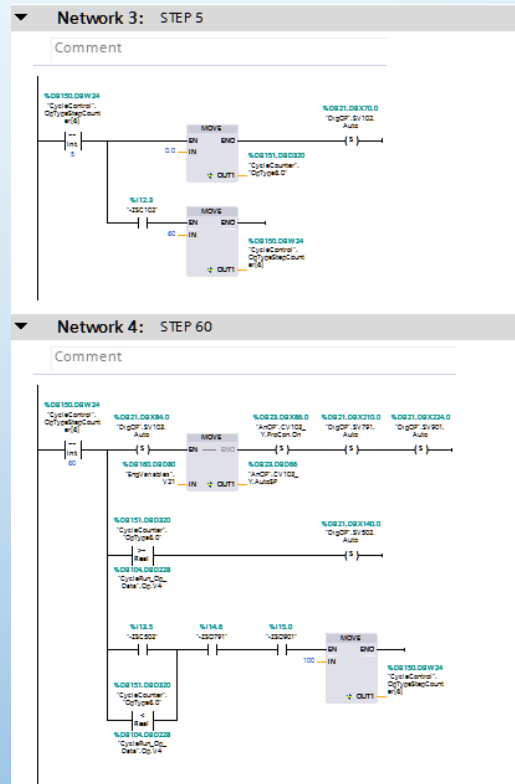
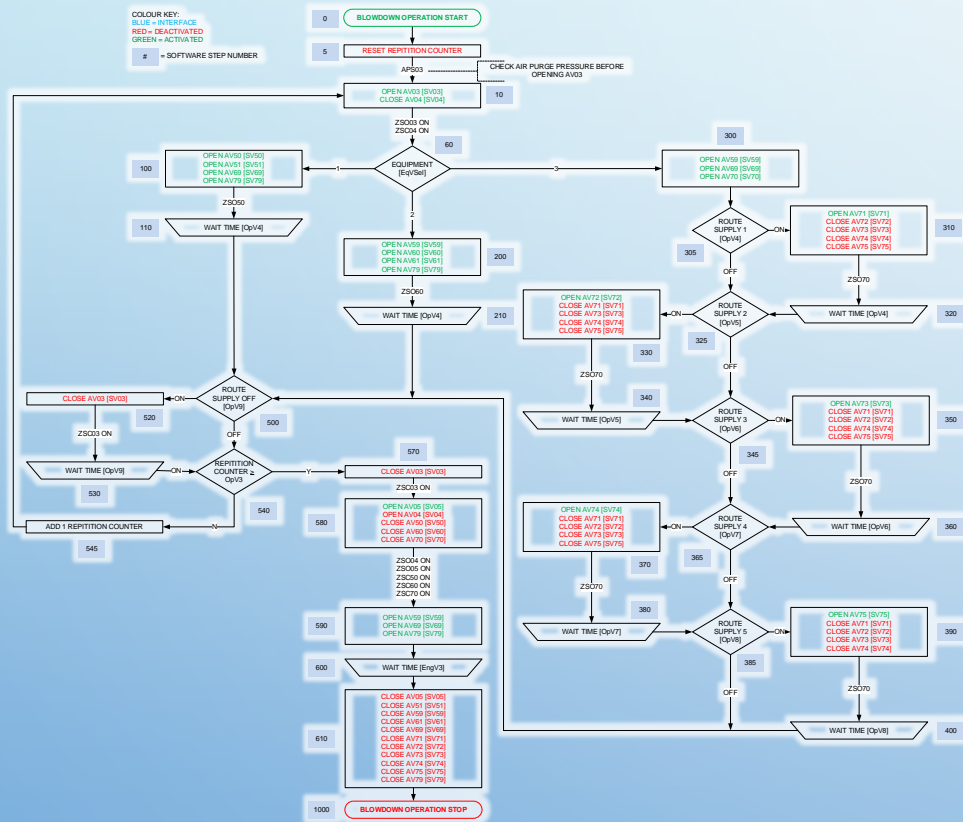

AUTOMATION BUILD

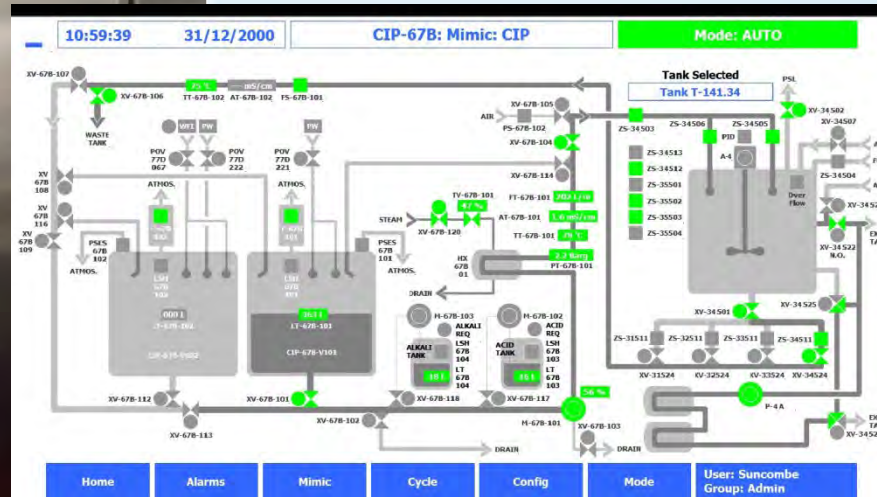

- LARGE HMI
- ROBUST
- INTUITIVE VISUALISATION
- 21CFR COMPLIANT
- REMOTE ACCESS CONTROL
- IPAD, IPHONE, ANDROID VIEWERS



PROJECT & QUALITY MANAGEMENT

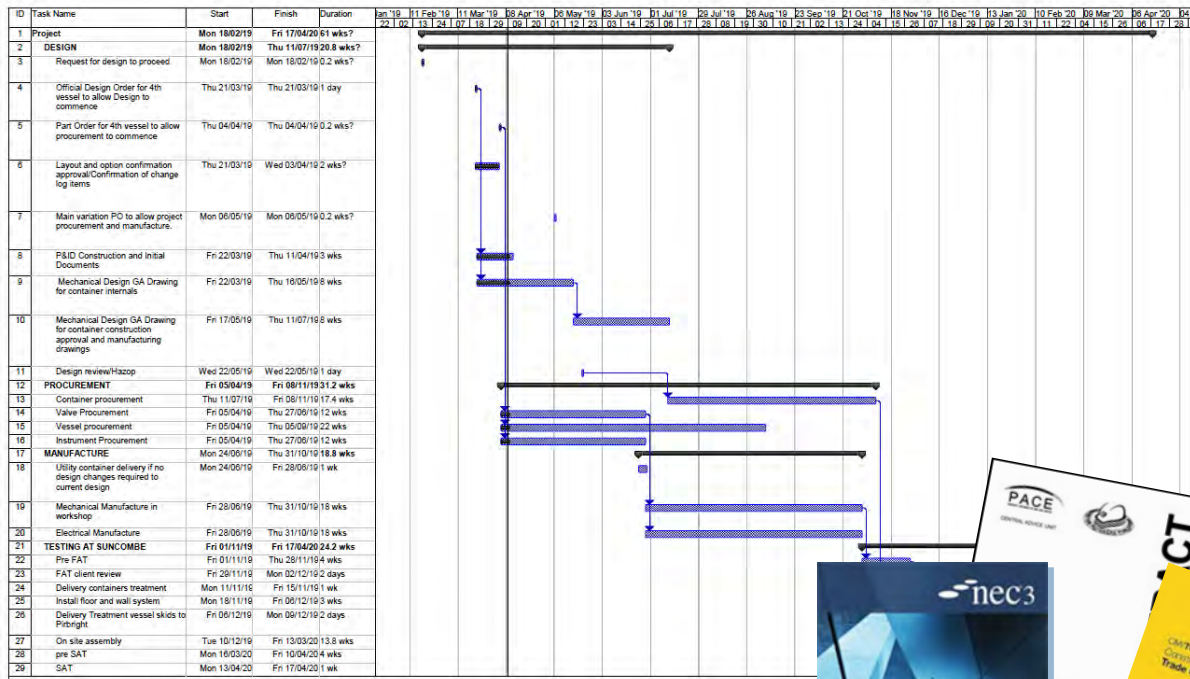

- QUALITY SYSTEMS
- PROGRAM CONTROL
- DOCUMENTATION CONTROL
- VALIDATION & COMPLIANCE
- CONTRACT MANAGEMENT



VALIDATION

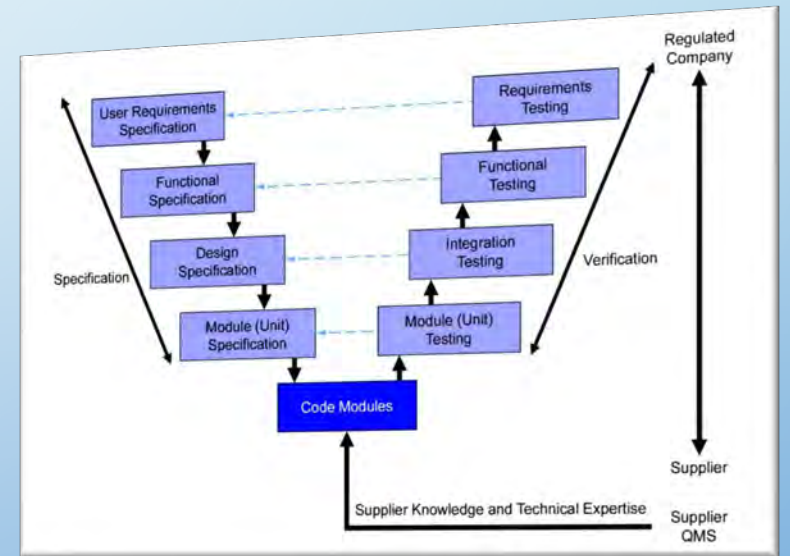

TESTING & TRAINING



- ✓ FACTORY ACCEPTANCE
- ✓ SITE ACCEPTANCE
- ✓ INSTALLATION QUALIFICATION
- ✓ OPERATION QUALIFICATION
- ✓ OPERATOR, ENGINEER & SERVICE TRAINING



DOCUMENTATION

- ✓ MECHANICAL, ELECTRICAL, PROCESS DESIGN DRAWINGS
- ✓ FUNCTIONAL, HARDWARE, SOFTWARE SPECIFICATIONS
- ✓ FACTORY & SITE ACCEPTANCE PROTOCOLS AND REPORTS
- ✓ CERTIFICATION AND CALIBRATION
- ✓ OPERATION & MAINTENANCE MANUALS
- ✓ ...AND MORE





WHEN QUALITY MATTERS
YOU CAN TRUST

SUNCOMBE

www.suncombe.com